



Foot Operated Hydraulic Pumps

Working pressure 700 bar

These pumps are one-way for single-acting hydraulic applications

Characteristics:

- Robust, durable and compact.
- For handsfree operation.
- Foot pedal lock and lightweight construction for easy carrying.
- Two-speed operation reduces foot pedal strokes.
- Large hand knob release valve for controlling load descent.
- Internal pressure relief valve for overload protection.
- Supplied with high pressure hose 1.8 meters and R2 3/8 quick coupler with dust cap.

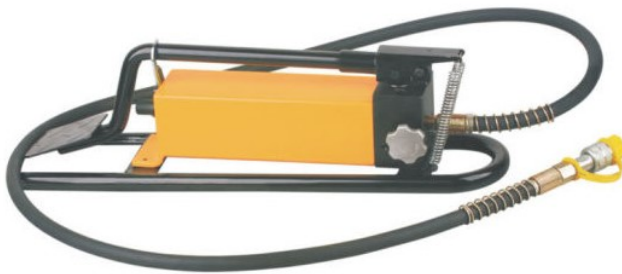

CFP-800B



CFP-800-1

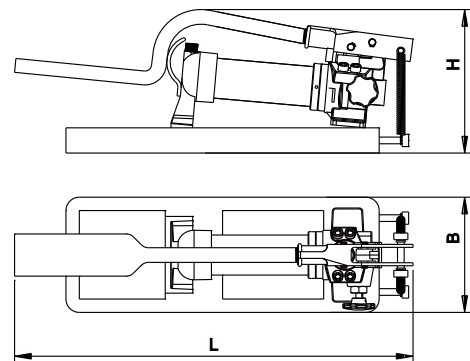
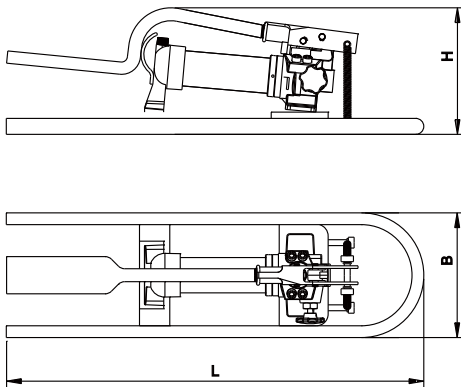

Model	Working pressure (bar)		Oil displacement per stroke (cm ³)		Reservoir (cm ³)		Dimensions (mm)			Packing size (cm)	Weight (Kg)
	Low pressure stage	High pressure stage	Low pressure stage	High pressure stage	Oil capacity	Usable oil capacity	L	B	H		
CFP-800-1	20	700	13	2.3	700	600	445	145	250	57x18x28	12.8
CFP-800B	20	700	13	2.3	1700	1500	450	150	200	62X16.5X19.5	12