

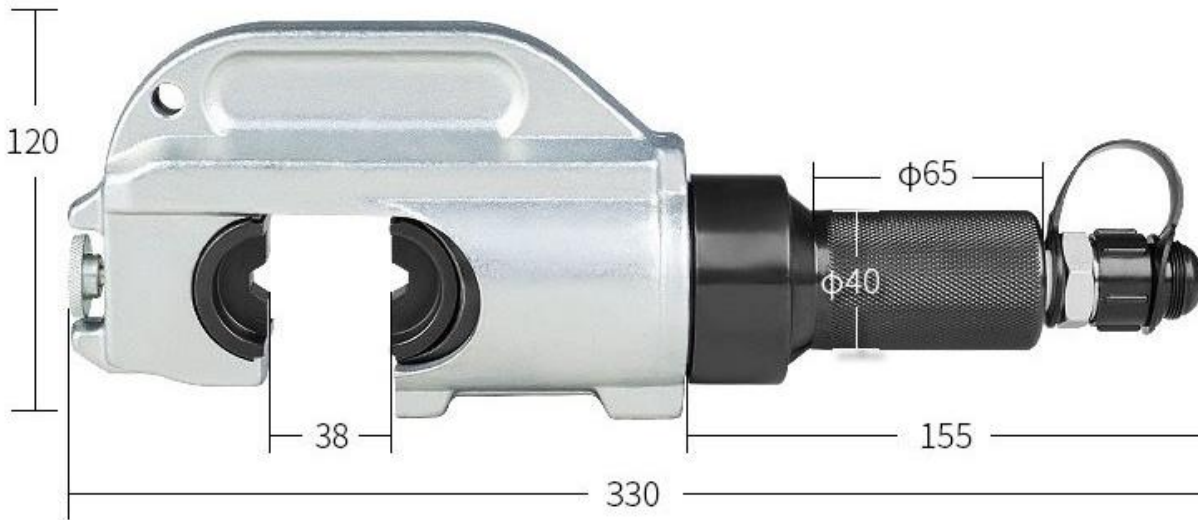

HYDRAULIC CRIMPING C HEAD EP SERIES

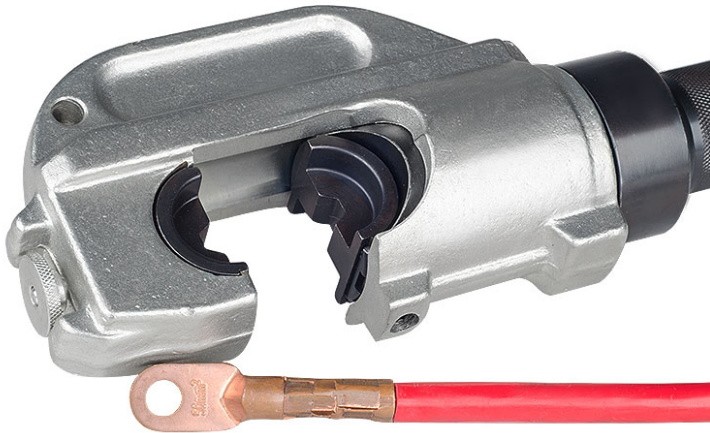



Specifications

Model	EP-510
Output	13 Ton
Stroke	38 mm
Crimping Range	16-400 mm ²
Crimping Dies	16,25,35,50,70,95,120,150,185 240,300,400 mm
Include	Plastic Box Extra Seal Set & Hex Key
Packing Weight	11kg
Packing Dimension	420x130x260 mm