



PUMPS
**HYDRAULIC
PUMPS**



Gasoline Powered Hydraulic Pumps

Gasoline Powered Hydraulic Pumps are a logical choice at work sites where electricity or compressed air are unavailable.

Characteristics:

- 6.5HP/5.5HP Briggs & Stratton engine.
- Manual control valve.
- High-pressure safety relief valve.
- Protective roll cage for use in tough environment.
- For use with either single or double acting tools.
- Each pump comes with 1.5 meter hose and R2 3/8 quick coupler with dust cap.



HHB-150B

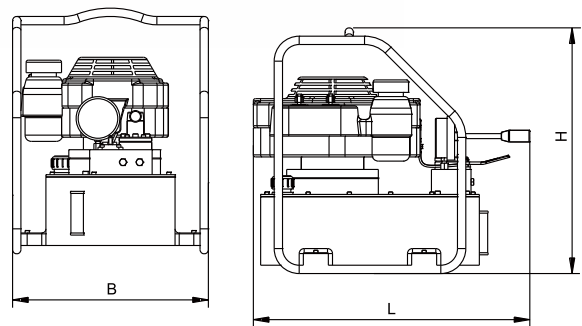

Model	Power rating (HP)	Working pressure (bar)		Flow rate (L/min)		Usable oil capacity (liter)	Dimensions (mm)			Packing size (cm)	Weight (Kg)
		Low pressure stage	High pressure stage	Low pressure stage	High pressure stage		L	B	H		
HHB-150B	5.5	20	700	6	0.9	15	580	360	480	63×44×62	48.2

