

10. Tool function diagram

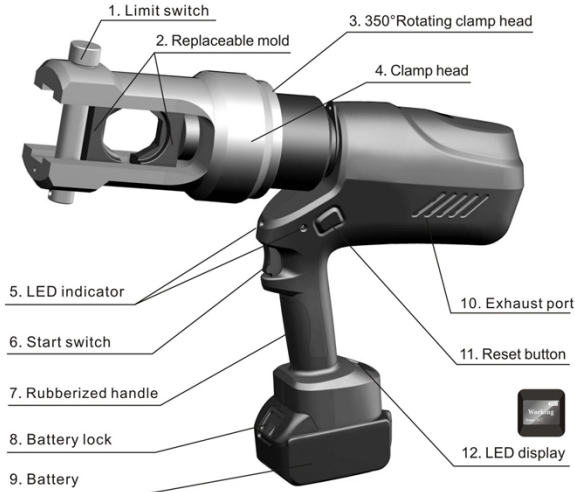

NO.	Describe	Function
1	Limit switch	Limiting die function
2	Replaceable mold	Crimp copper and aluminum terminals, connecting pipes
3	350° Rotating clamp head	Limit to prevent the clamp head from rotating out
4	Clamp head	Crimping joint
5	LED indicator	Lighting function
6	Start switch	Tool operation start switch
7	Rubberized handle	Non-slip
8	Battery lock	Prevent the battery from loosening
9	Battery	Power supply, rechargeable lithium battery (18V)
10	Exhaust port	Cooling cycle
11	Reset button	Manual pressure relief in case of operating errors
12	LED display	Display power, frequency, pressure, temperature

HYDRAULIC TOOLS

BATTERY HYDRAULIC CRIMPING TOOL

WARRANTY

Series name:	Model:	
Customer:		
Address:		Postal code:
Telephone:		Mail:
Dealer:		
Invoice number:		Sale date: / /
Supplier name:		Telephone:
Company seal:		



For non-conformances in the manufacturing process, enjoy the following warranty period. Calculated from the date of purchase: non-artificial warranty for one year

The warranty will be carried out under the following conditions:

Consumers must present the invoice for the purchase tool and the warranty certificate correctly filled in and stamped by the purchase store.

Loss of warranty:

- Failure to comply with one or more of the following assumptions will void the warranty.
 - If the product has been opened, altered, adjusted or repaired by persons not authorized by EMEADS;
 - If any part, component or assembly of the product is deemed to be non-original;
 - Lack of equipment maintenance;
 - Parts and components wear out naturally.
- Except for the natural wear, drop, impact, improper use of tools or improper design of product parts and components, they are not covered by the warranty.
- Before obtaining authorized technical support, this guarantee does not include the freight or transportation cost of the tool, and the cost shall be borne by the customer.

HYDRAULIC TOOLS BATTERY HYDRAULIC CRIMPING TOOL



EB-630

EBS-630

EBS type includes continuous use function.

Instruction Manual

Please read it before use



HYDRAULIC CRIMPING TOOL

1. General guide



Read this manual before using EB-630/EBS-630 hydraulic crimping pliers, keep the manual for future reference or to pass information to others who operate the equipment.

Note: When using hydraulic crimping pliers, basic safety precautions must be followed to avoid accidents.

2. Symbols and their meaning

Symbol	Name	Explain
	Notice	Safety warning and attention to accident hazards during use
	Read the operating/ instruction manual	Before using the device, please read the instruction manual
	Use PPE (Personal Protective Equipment)	Use personal protective equipment suitable for all kinds of jobs
	Keep others away	To reduce the risk of accidents, please keep others away from the environment where the equipment is used
	Selective disposal	According to the current laws and regulations of your city, handle the packaging correctly to avoid polluting rivers, streams and other water sources

3. Safety instructions

3.1 Operational safety



Note: This tool is not suitable for people with physical, sensory, or mental abilities (including children), or people who lack experience and knowledge, unless they have received instructions on using the tool or are under someone's supervision. They are responsible for their safety.

- Hydraulic crimping tools can only be used by persons who have read and understood this manual;
- Keep this tool out of reach of children;
- Do not use tools without a matrix;
- Do not put your fingers between the molds, and do not check for leaks with your hands;
- Only use original accessories to ensure tool safety;
- Be vigilant when using tools. If you feel tired under the influence of alcohol, drugs or drugs, do not use this tool. A momentary negligence in operating hydraulic tools may cause serious accidents.

3.2 Equipment inspection

When starting to use, check the tool carefully to check for any malfunctions or non-compliance. If you find any abnormalities or non-compliance, you can contact Imiz through the website www.emeads.com.

3.3 Safe for cleaning and maintenance



Note: Do not replace the tool handle with non-original parts.

- Follow the instructions to replace the accessories correctly;
- Always keep the handle of the tool held by the operator dry and free of oil or grease.

HYDRAULIC CRIMPING TOOL



Note: Please use PPE (Personal Protective Equipment) when using the product, such as safety glasses, Protective gloves and earmuffs.

4. Function Description

4.1 Over temperature protection alarm function

In working mode or aging mode, when the detection temperature exceeds 70 degrees, it will enter the temperature protection state, the motor will be turned off to ensure the safety of the equipment, and the detection temperature will automatically be released when the detection temperature drops below 70 degrees. Display alarm content: [OVER TEMP PROT].

5. Technical parameter

Remarks: EBS type includes continuous use function.

Model No:	EB-630 / EBS-630
Crimping force:	200KN
Stroke:	20mm
Crimping times:	120times(Cu150mm ²) (Per saturation voltage)
Crimping cycle:	6-18s (Depend on the size of cable)
Voltage/capacity:	18V/4.0Ah
Gross weight/Net weight:	17kg/7.8kg
Charging time:	1.0hours
Package:	Plastic box
ACCESSORIES:	
Crimping dies:	25,35,50,70,95,120,150,185,240,300,400,500,630mm ²
Battery:	2pcs
Charger:	1pc
Cylinder seal ring:	1set
Safety valve seal ring:	1set

6. Maintenance knowledge

Electric hydraulic pliers should be maintained frequently. Don't just use it and forget the importance of maintenance. Clean the surface of the tool and the dust in the gap.

- Do not start crimping without installing a crimping die to avoid damaging the clamp head.
- Try to avoid unnecessary air pressure no-load operation, which will affect the learning and memory ability of the intelligent circuit board.
- There is a guide groove on the piston and a proper amount of lubricating oil is applied to the piston.
- Check the battery every 30 days and charge it to a saturated state to avoid damage to the battery due to long-term power loss.
- Clean the crimping mold in time and apply anti-rust oil to prevent the mold from rusting and crimping.

HYDRAULIC CRIMPING TOOL

7. Description of the main functions of the tool



The hydraulic equipment includes an automatic reset device, which can reset the piston when the piston reaches a greater output force.



The manual reset device can manually reset the piston in the event of an operating error.



The head can be rotated 350° to adapt to the angle of operation and to operate in difficult environments.



When an error occurs, an alarm sounds and the indicator light is on.



One-button control, only one button, more convenient to hold than two buttons.



Lithium battery has no memory effect and no automatic discharge. It can be used at any time if not used for a long time. In addition, compared with nickel-hydrocarbon batteries, the storage capacity is 50% higher, and the charging is fast and the time is short.



The temperature sensor makes the tool automatically stop working when the working temperature reaches 60°C for a long time, and an error sound is displayed, indicating that the tool can no longer continue to work until the temperature drops to normal.

Hardware function description	LED light shows red	LED light shows white	Beep
Battery	First it indicates for one second, then flashes for two seconds and goes out	X	X
Push the trigger (motor work)	X	Bright	X
Release the trigger (the motor stops working)	X	Turns off after 20 seconds of continuous light	X
Push the trigger again within 20 seconds after releasing the trigger	X	Bright	X
Low battery (motor does not work)	Flash for three seconds	X	Sound 3 times at the same time
Low battery (motor working)	3 seconds on	X	3 beeps

8. Operation guide

Please check carefully before operation to ensure that the tool is intact. Put the battery into the charger and connect the plug to the socket. Ensure that the room temperature is between 10°C-40°C, and the charging time is about 1.0 hours. As shown on the right:



1.

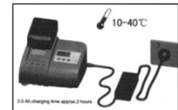

2.

9. Tool use

- First, you must check whether the LED indicator is on. If the indicator light is on for more than 5 seconds, it means that the battery is out of power, and a fully charged battery loading tool should be replaced.
- Choose the right mold according to your needs.



Note: Do not operate tools without molds installed.



Note: Loosen the trigger to stop the crimping at any time.